



DEVELOPMENT PERMIT APPLICATION

APPLICATION NO.	PRDP20243060
ROLL NO.	03329054
RENEWAL OF	
FEES PAID	\$2,150.00
DATE OF RECEIPT	May 16, 2024

APPLICANT/OWNER						
Applicant Name: Vivian Dinh			Email: vivian.dinh@sonroc.ca			
Business/Organization Name (if applicable): Sonroc Group Ltd.						
Mailing Address: 5104-7005 Fairmount Dr SE, Calgary, AB				Postal Code: T2H 0K4		
Telephone (Primary): (587)390-4008 ext. 3135			Alternative:			
Landowner Name(s) per title (if not the Applicant): Richard Thome						
Business/Organization Name (if applicable): The Welding Shop						
Mailing Address: 5110 - 76 Ave SE				Postal Code: T2C 2X2		
Telephone (Primary): (403)273-7717			Email: rthome@twscalgary.com			
LEGAL LAND DESCRIPTION - Subject site						
All/part of:	NW ¼	Section: 29	Township: 23	Range: 28	West of: 4 Meridian	Division:
All parts of : Lot 9		Block: 11	Plan: 221 0706	Parcel Area (ac/ha):		
Municipal Address: 83 Heatherglen Place				Land Use District: Direct Control (DC-__161__)		
APPLICATION FOR - List use and scope of work						
Proposed development consists of a steel fabrication welding shop (footprint: 13,000ft ² /1207.74m ²) with 2-storey office portion (total area of 3,900ft ² / 362.3m ²)						
Variance Rationale included: <input type="checkbox"/> YES <input type="checkbox"/> NO <input checked="" type="checkbox"/> N/A DP Checklist Included: <input checked="" type="checkbox"/> YES <input type="checkbox"/> NO Name of RVC Staff Member Assisted:						
SITE INFORMATION						
a. Oil or gas wells present on or within 100 metres of the subject property(s)				<input type="checkbox"/> YES <input checked="" type="checkbox"/> NO		
b. Parcel within 1.5 kilometres of a sour gas facility (well, pipeline or plant)				<input type="checkbox"/> YES <input checked="" type="checkbox"/> NO		
c. Abandoned oil or gas well or pipeline present on the property (Well Map Viewer: https://extmapviewer.aer.ca/AERAbandonedWells/Index.html)				<input checked="" type="checkbox"/> YES <input type="checkbox"/> NO		
d. Subject site has direct access to a developed Municipal Road (accessible public roadway)				<input checked="" type="checkbox"/> YES <input type="checkbox"/> NO		
AUTHORIZATION						
I, <u>VIVIAN DINH</u> (Full name in Block Capitals), hereby certify (initial below):						
<u> </u> That I am the registered owner OR <input checked="" type="checkbox"/> That I am authorized to act on the owner's behalf.						
<input checked="" type="checkbox"/> That the information given on this form and related documents, is full and complete and is, to the best of my knowledge, a true statement of the facts relating to this application.						
<input checked="" type="checkbox"/> That I provide consent to the public release and disclosure of all information, including supporting documentation, submitted/contained within this application as part of the review process. I acknowledge that the information is collected in accordance with s.33(c) of the <i>Freedom of Information and Protection of Privacy Act</i> .						
<input checked="" type="checkbox"/> Right of Entry: I authorize/acknowledge that Rocky View County may enter the above parcel(s) of land for purposes of investigation and enforcement related to this application in accordance with Section 542 of the Municipal Government Act.						
Applicant Signature <u></u>			Landowner Signature _____			
Date <u>07-May-2024</u>			Date _____			

ENCUMBRANCES, LIENS & INTERESTS

PAGE 2

221 103 114 +6

REGISTRATION

NUMBER	DATE (D/M/Y)	PARTICULARS
221 102 787	17/05/2022	ENCUMBRANCE ENCUMBRANCEE - HEATHERGLEN BUSINESS PARK OWNERS' ASSOCIATION. 100 GLENEAGLES DRIVE COCHRANE ALBERTA T4C1P5
221 103 115	17/05/2022	RESTRICTIVE COVENANT
221 103 116	17/05/2022	CAVEAT RE : DEVELOPMENT AGREEMENT PURSUANT TO MUNICIPAL GOVERNMENT ACT CAVEATOR - ROCKY VIEW COUNTY. 262075 ROCKY VIEW POINT ROCKY VIEW COUNTY ALBERTA T4A0X2
221 103 121	17/05/2022	UTILITY RIGHT OF WAY GRANTEE - TELUS COMMUNICATIONS INC. GRANTEE - SHAW CABLESYSTEMS LIMITED. GRANTEE - ATCO GAS AND PIPELINES LTD. GRANTEE - FORTISALBERTA INC. GRANTEE - ENMAX POWER CORPORATION. GRANTEE - HGBP HOLDING CORPORATION LTD. GRANTEE - ROCKY VIEW COUNTY. GRANTEE - HEATHERGLEN BUSINESS PARK OWNERS' ASSOCIATION. AS TO PORTION OR PLAN:2210709
221 103 123	17/05/2022	UTILITY RIGHT OF WAY GRANTEE - HGBP HOLDING CORPORATION LTD. GRANTEE - ROCKY VIEW COUNTY. GRANTEE - HEATHERGLEN BUSINESS PARK OWNERS' ASSOCIATION. AS TO PORTION OR PLAN:2210710
221 103 125	17/05/2022	UTILITY RIGHT OF WAY GRANTEE - HGBP HOLDING CORPORATION LTD. GRANTEE - ROCKY VIEW COUNTY. GRANTEE - HEATHERGLEN BUSINESS PARK OWNERS' ASSOCIATION. AS TO PORTION OR PLAN:2210711

TOTAL INSTRUMENTS: 007

(CONTINUED)

THE REGISTRAR OF TITLES CERTIFIES THIS TO BE AN
ACCURATE REPRODUCTION OF THE CERTIFICATE OF
TITLE REPRESENTED HEREIN THIS 7 DAY OF MAY,
2024 AT 04:25 P.M.

ORDER NUMBER: 50447907

CUSTOMER FILE NUMBER:



END OF CERTIFICATE

THIS ELECTRONICALLY TRANSMITTED LAND TITLES PRODUCT IS INTENDED
FOR THE SOLE USE OF THE ORIGINAL PURCHASER, AND NONE OTHER,
SUBJECT TO WHAT IS SET OUT IN THE PARAGRAPH BELOW.

THE ABOVE PROVISIONS DO NOT PROHIBIT THE ORIGINAL PURCHASER FROM
INCLUDING THIS UNMODIFIED PRODUCT IN ANY REPORT, OPINION,
APPRAISAL OR OTHER ADVICE PREPARED BY THE ORIGINAL PURCHASER AS
PART OF THE ORIGINAL PURCHASER APPLYING PROFESSIONAL, CONSULTING
OR TECHNICAL EXPERTISE FOR THE BENEFIT OF CLIENT(S).



Sonroc Group Ltd.
 5104-7005 Fairmount Dr SE, Calgary, AB T2H 0K4
 P: (587) 390-4008 F: (587) 390-4018
 www.sonroc.ca

Rocky View County
 Planning & Development Services
 262075 Rocky View Point,
 Rocky View, AB
 T4A 0X2

Planning Analysis for Proposed Development at:

Lot 9, Block 11, Plan 332 0706
N.W. 1/4 Section 29 Township 23 Range 28 W4M

To Whom It May Concern,

The following is a general summary of the proposed development permit application for the **The Welding Shop** at the above noted property.

Business Location

Subject property is located East of Calgary, East of Stony Trail & North of Glenmore Trail.



Fig 1. Vicinity Plan of The Welding Shop.



Sonroc Group Ltd.
5104-7005 Fairmount Dr SE, Calgary, AB T2H 0K4
P: (587) 390-4008 F: (587) 390-4018
www.sonroc.ca

Business Activities

The Welding Shop was founded in June of 1969 and based in Calgary, AB dedicated to providing the highest level of professional service to the welding industry. The new modern building with $\pm 1,389\text{m}^2/\pm 14,950.0\text{ft}^2$ building footprint, including a 2-story office portion with a total area of $\pm 362\text{m}^2/\pm 3900\text{ft}^2$. The building exterior utilizes architectural metal cladding and high-performance materials that give it a sleek look for neighboring properties.

The proposed development has planned 32 parking stalls for employees and guests of the office including 2 barrier free parking stalls. There will be an exterior crane on the southside of the building and there is 1 access to this site from Heatherglen Place allowing for easy flow of traffic in and out of the parking development.

For details on the business operations, please refer to the next page.

We trust the above is satisfactory. Please contact us if there are any questions or concerns.

Regards,

SONROC GROUP LTD



The Welding Shop
5110 – 76th Ave S.E.
Calgary, AB – T2C 2X2

Ph: 403-273-7717

Date: May 5 2024

To Whom It May Concern:

- Operational letter:
 - Standard days of operation: Monday to Friday 6 AM to 6 PM
 - Number of employees: 20 - 25. Standard building occupancy at one time 10-15
 - Description of work operations: Structural steel and miscellaneous metal fabrication

Sincerely,

Richard Thome



5104 – 7005 Fairburn Avenue SE
Calgary, AB T2H 0K4
587.390.4008
info@sonroc.ca
www.sonroc.ca

Example of crane system:



THE WELDING SHOP HEATHERGLEN INDUSTRIAL
83 HEATHERGLEN PLACE, ROCKY VIEW, ALBERTA

LOT 9, BLOCK 11, PLAN 221 0706



Picture 1



Picture 2

Photos taken on May 07, 2024

THE WELDING SHOP HEATHERGLEN INDUSTRIAL
83 HEATHERGLEN PLACE, ROCKY VIEW, ALBERTA

LOT 9, BLOCK 11, PLAN 221 0706



Picture 3



Picture 4

Photos taken on May 07, 2024

THE WELDING SHOP HEATHERGLEN INDUSTRIAL
83 HEATHERGLEN PLACE, ROCKY VIEW, ALBERTA

LOT 9, BLOCK 11, PLAN 221 0706



Picture 5



Picture 6

Photos taken on May 07, 2024

THE WELDING SHOP HEATHERGLEN INDUSTRIAL
83 HEATHERGLEN PLACE, ROCKY VIEW, ALBERTA

LOT 9, BLOCK 11, PLAN 221 0706



Picture 7



Picture 8

Photos taken on May 07, 2024

THE WELDING SHOP HEATHERGLEN INDUSTRIAL
83 HEATHERGLEN PLACE, ROCKY VIEW, ALBERTA

LOT 9, BLOCK 11, PLAN 221 0706



Picture 9



Picture 10

Photos taken on May 07, 2024

THE WELDING SHOP HEATHERGLEN INDUSTRIAL
83 HEATHERGLEN PLACE, ROCKY VIEW, ALBERTA

LOT 9, BLOCK 11, PLAN 221 0706



Picture 11



Picture 12

Photos taken on May 07, 2024

THE WELDING SHOP HEATHERGLEN INDUSTRIAL
83 HEATHERGLEN PLACE, ROCKY VIEW, ALBERTA

LOT 9, BLOCK 11, PLAN 221 0706



Picture 13



Picture 14

Photos taken on May 07, 2024

THE WELDING SHOP HEATHERGLEN INDUSTRIAL
83 HEATHERGLEN PLACE, ROCKY VIEW, ALBERTA

LOT 9, BLOCK 11, PLAN 221 0706



Picture 15



Picture 16

Photos taken on May 07, 2024

THE WELDING SHOP HEATHERGLEN INDUSTRIAL
83 HEATHERGLEN PLACE, ROCKY VIEW, ALBERTA

LOT 9, BLOCK 11, PLAN 221 0706



Picture 17

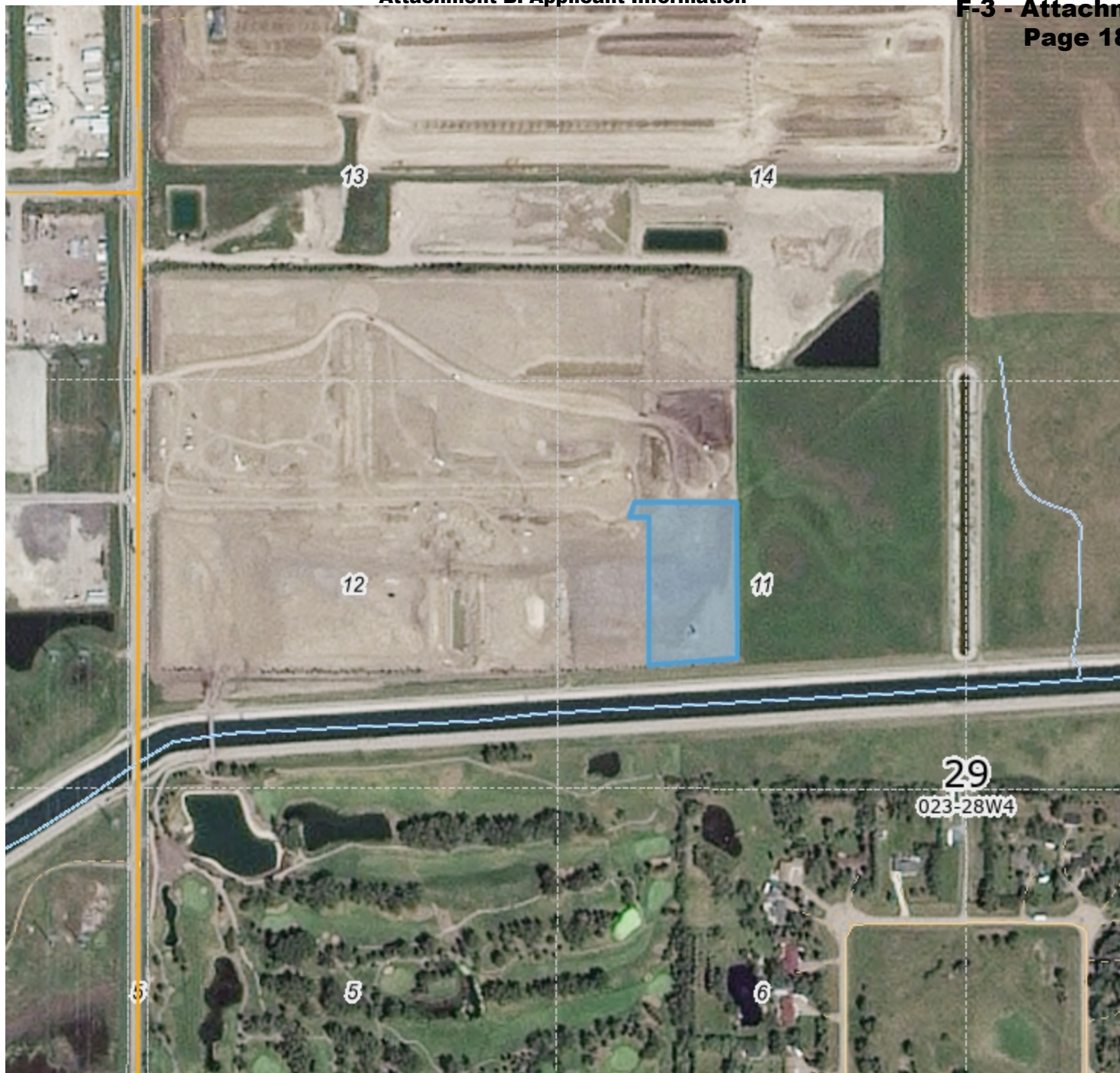

Abandoned Well Map

Base Data provided by: Government of Alberta

Author Sonroc Group Ltd.

Printing Date: 5/7/2024

Date Date (if applicable)

The Alberta Energy Regulator (AER) has not verified and makes no representation or warranty as to the accuracy, completeness, or reliability of any information or data in this document or that it will be suitable for any particular purpose or use. The AER is not responsible for any inaccuracies, errors or omissions in the information or data and is not liable for any direct or indirect losses arising out of any use of this information. For additional information about the limitations and restrictions applicable to this document, please refer to the AER Copyright & Disclaimer webpage: <http://www.aer.ca/copyright-disclaimer>.

Scale: 9,027.98

0.14 Kilometers 0

Projection and Datum:

WGS84 Web Mercator Auxiliary Sphere



Legend

- ◇ Abandoned Well (Large Scale)
- Revised Well Location (Large Scale)
- Revised Location Pointer
- Paved Road (20K)
 - Primary Divided
 - Primary Undivided 4L
 - Primary Undivided 2L
 - Primary Undivided 1L
 - Interchange Ramp
 - Secondary Divided
 - Secondary Undivided 4L



5104-7005 Fairmount Drive SE Calgary, AB T2H 0K4
T: 587.390.4008 www.sonroc.ca



LAU ARCHITECTURE
& URBAN DESIGN

STAMPS

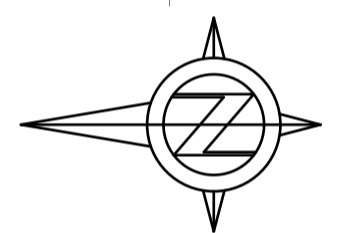
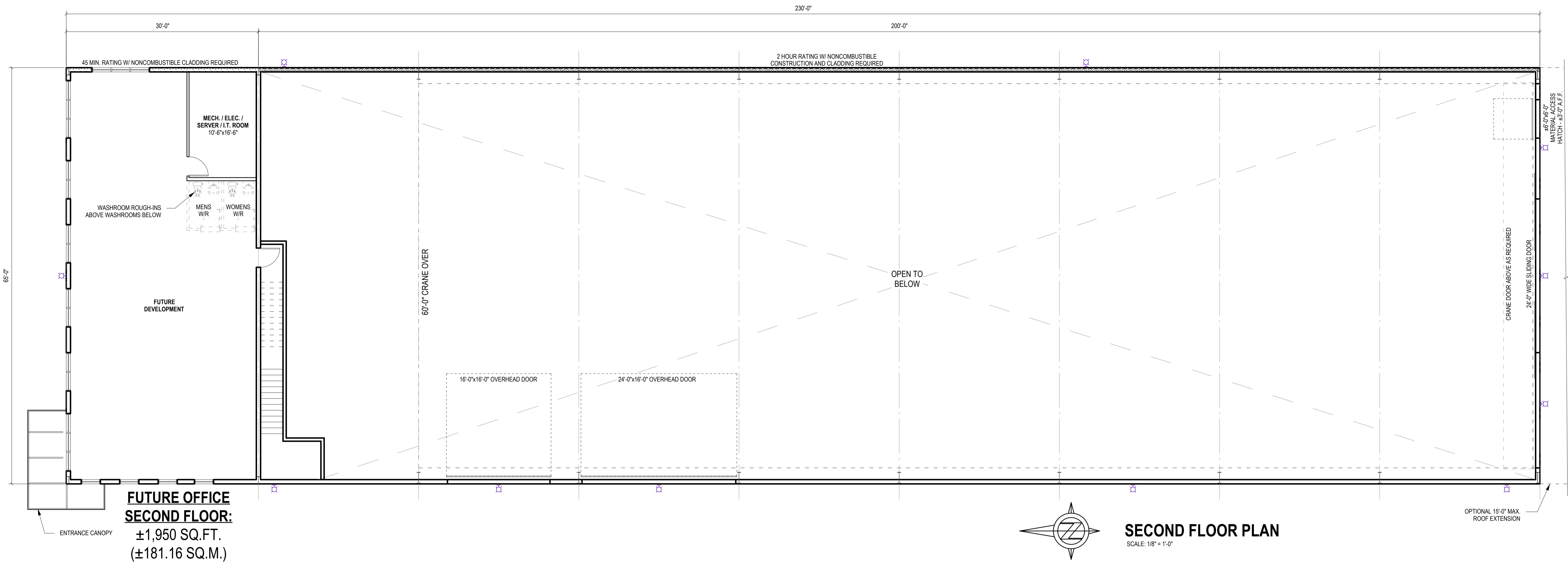

SECOND FLOOR PLAN
SCALE: 1/8" = 1'-0"

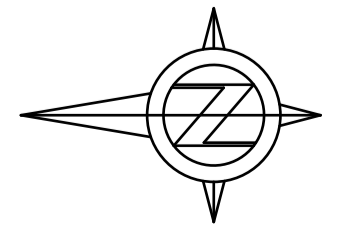
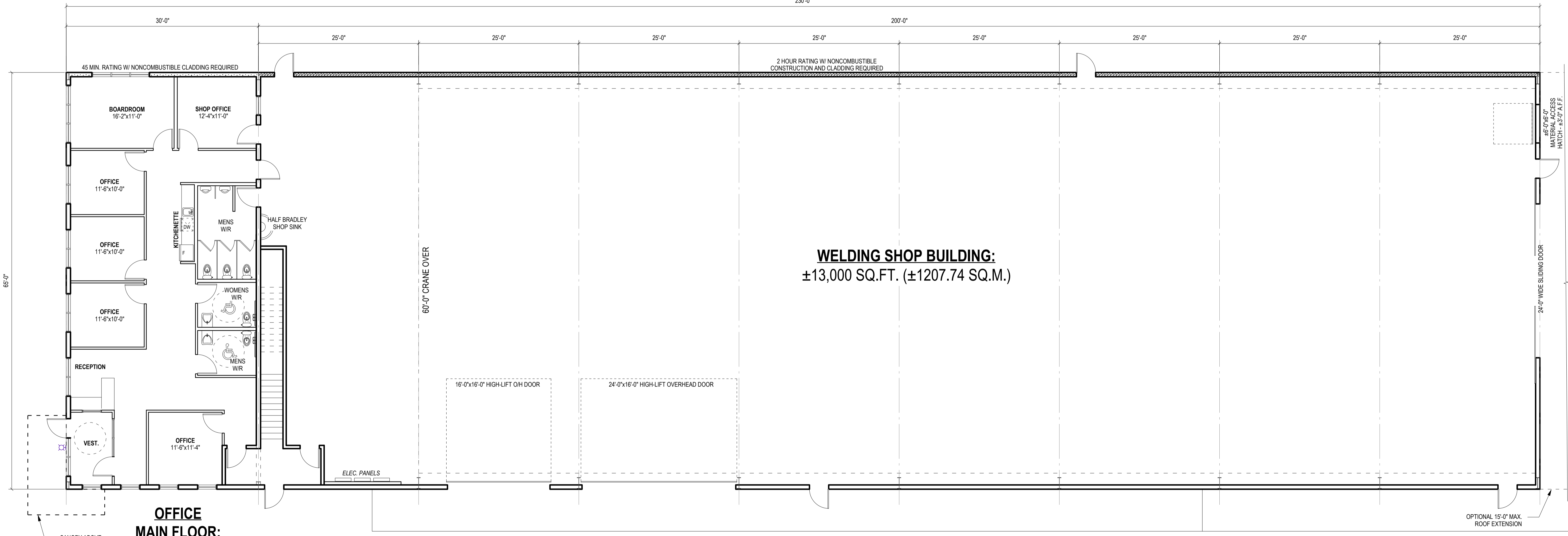

MAIN FLOOR PLAN
SCALE: 1/8" = 1'-0"

SITE INFORMATION	
LEGAL DESCRIPTION:	LOT 9, BLOCK 11, PLAN 221 0706
MUNICIPAL ADDRESS:	83 HEATHERGLEN PLACE

NO.	DESCRIPTION	DATE	BY
0	Issued for Development Permit	May 06/24	CR
REVISIONS			
CLIENT			
THE WELDING SHOP			
CALGARY		ALBERTA	
PROJECT			
THE WELDING SHOP			
ROCKY VIEW COUNTY		ALBERTA	
TITLE			
FLOOR PLANS			
PROJECT NO. SR24-799			
DRAWN	DATE		
CGR	JAN. 31, 2024		
CHECKED	DATE		
SJD	----		
SCALE AS NOTED			
DRAWING NO. DP3			

STAMPS

SITE INFORMATION

LEGAL DESCRIPTION: LOT 9, BLOCK 11, PLAN 221 0706
MUNICIPAL ADDRESS: 83 HEATHERGLEN PLACE

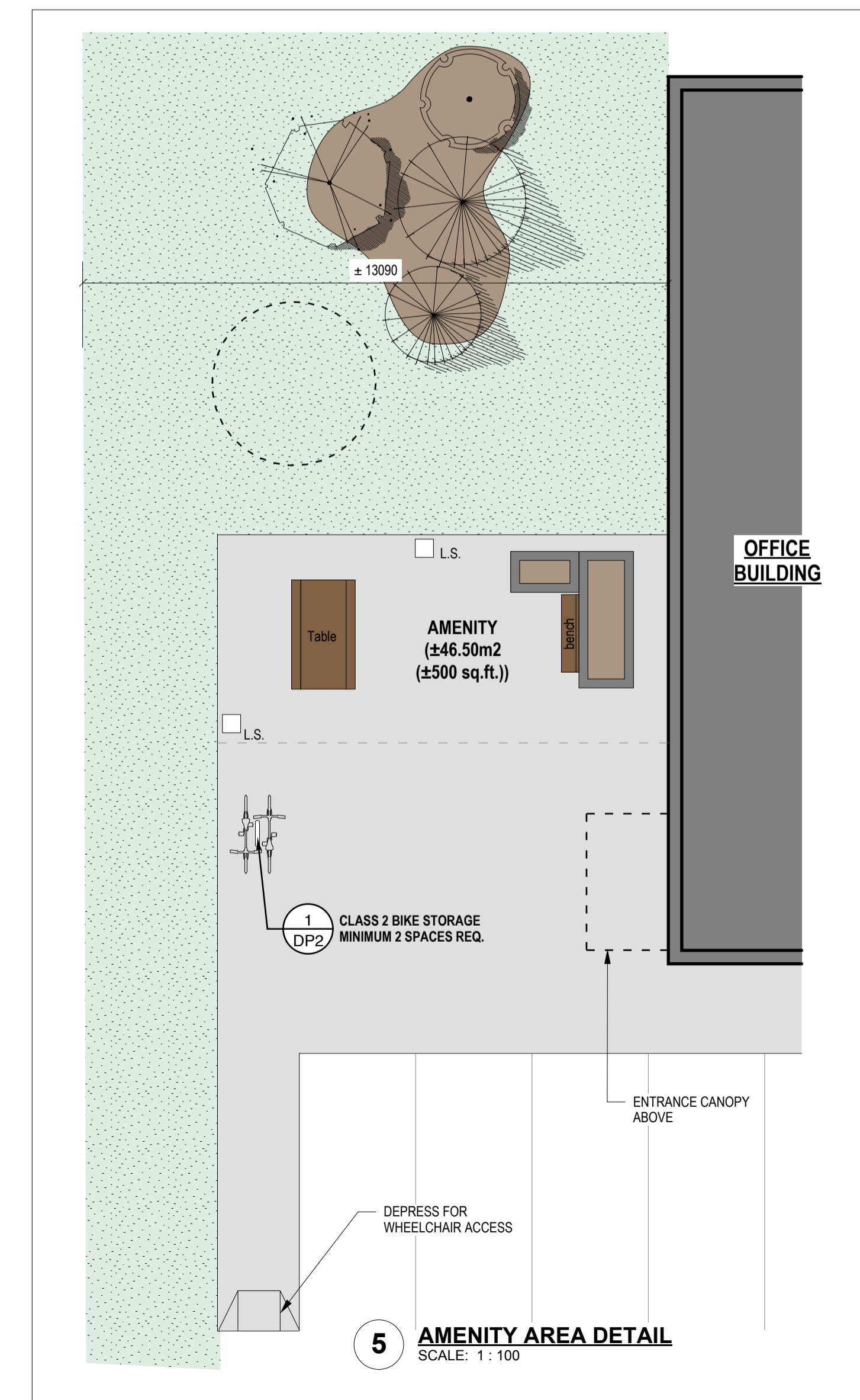
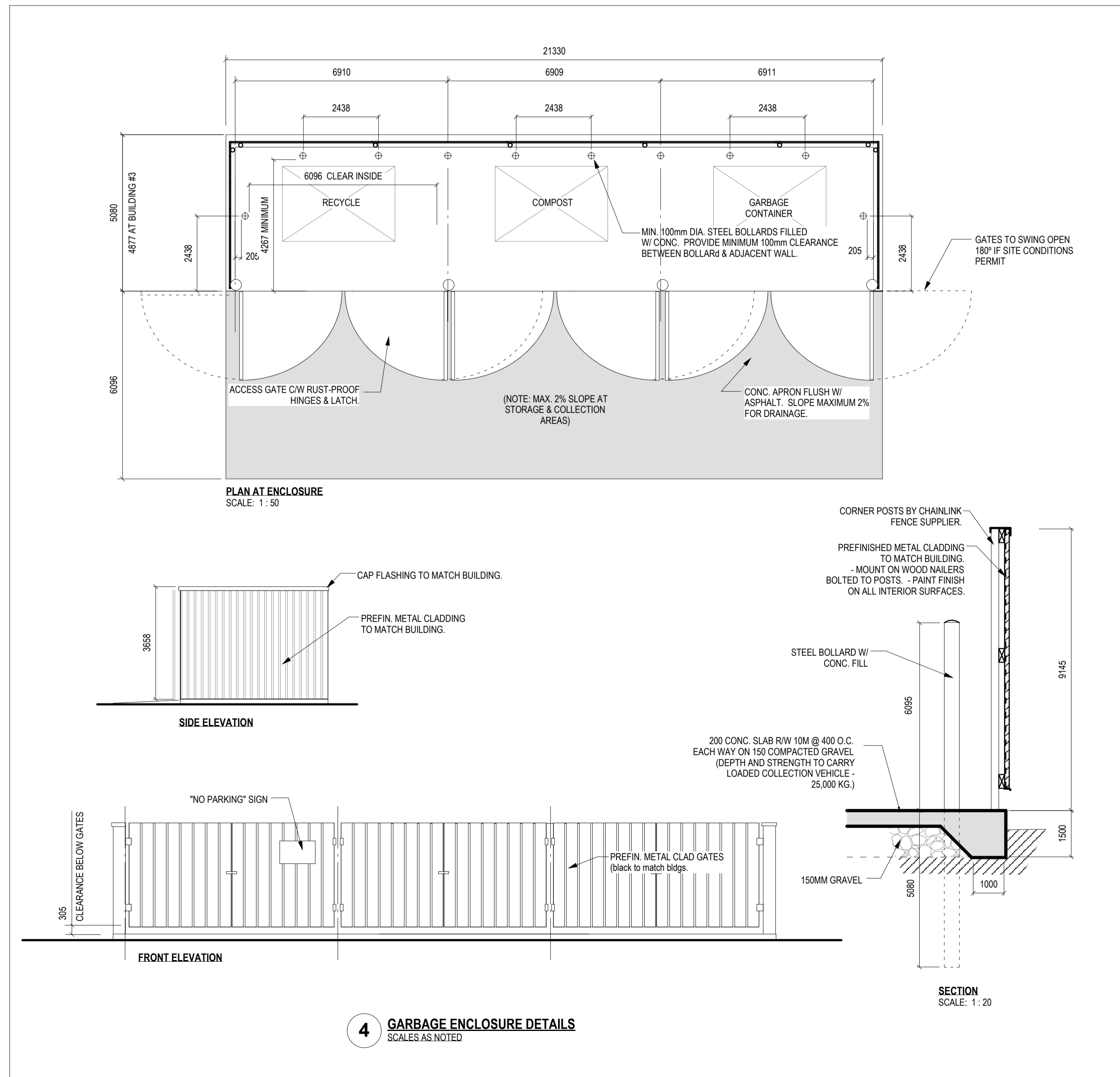
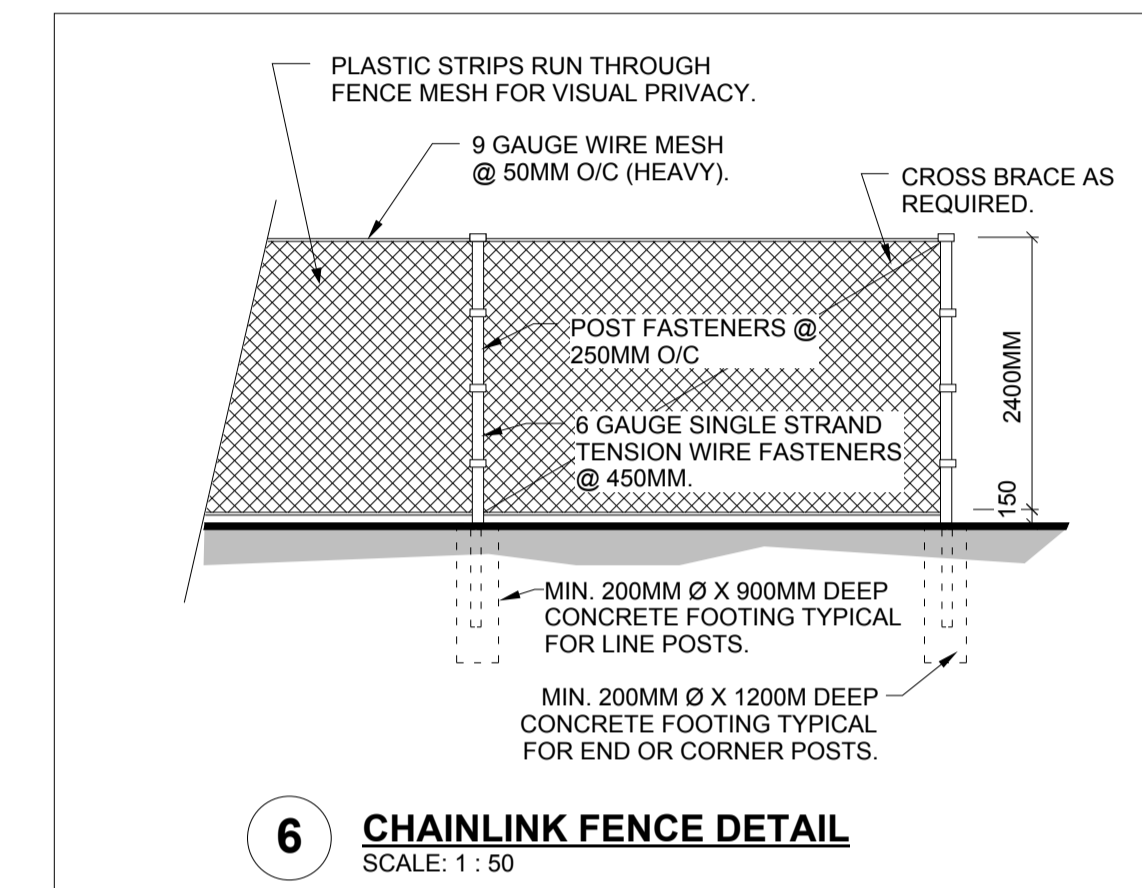
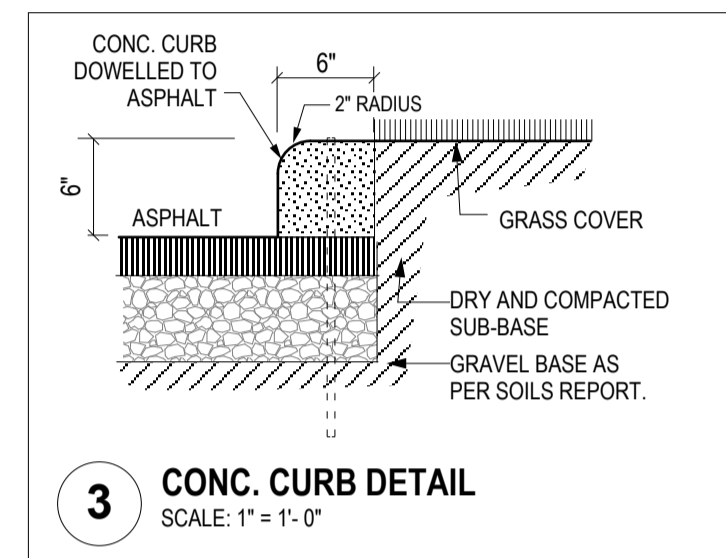
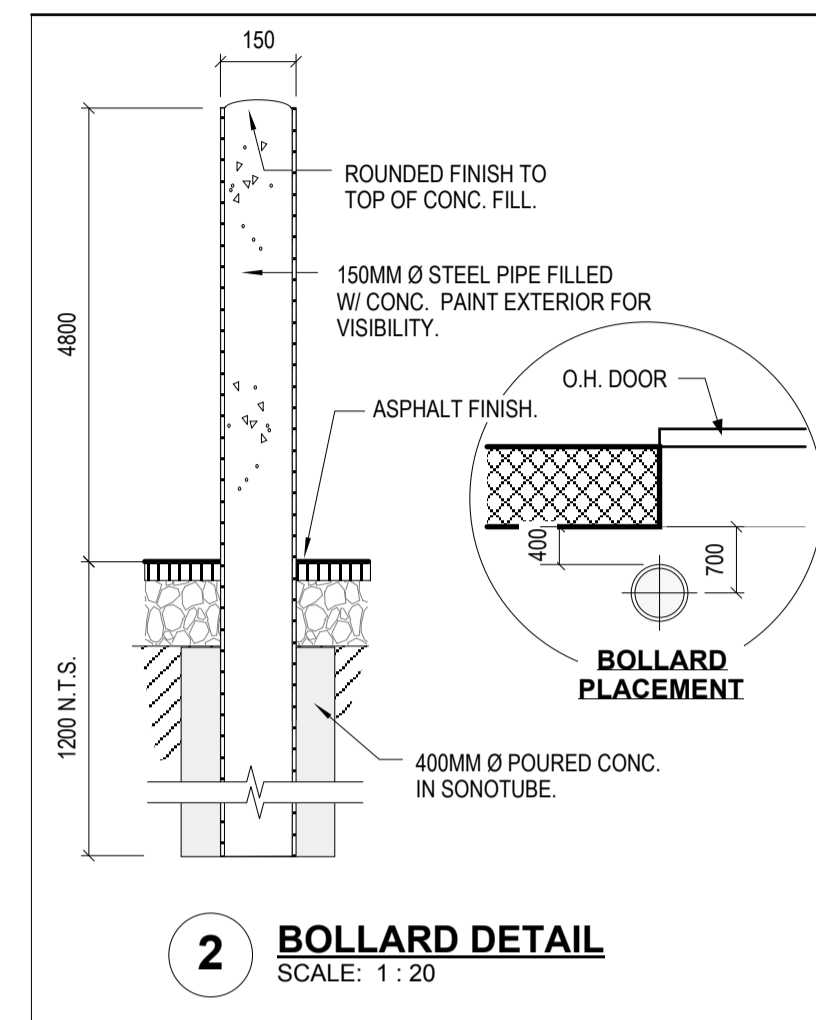
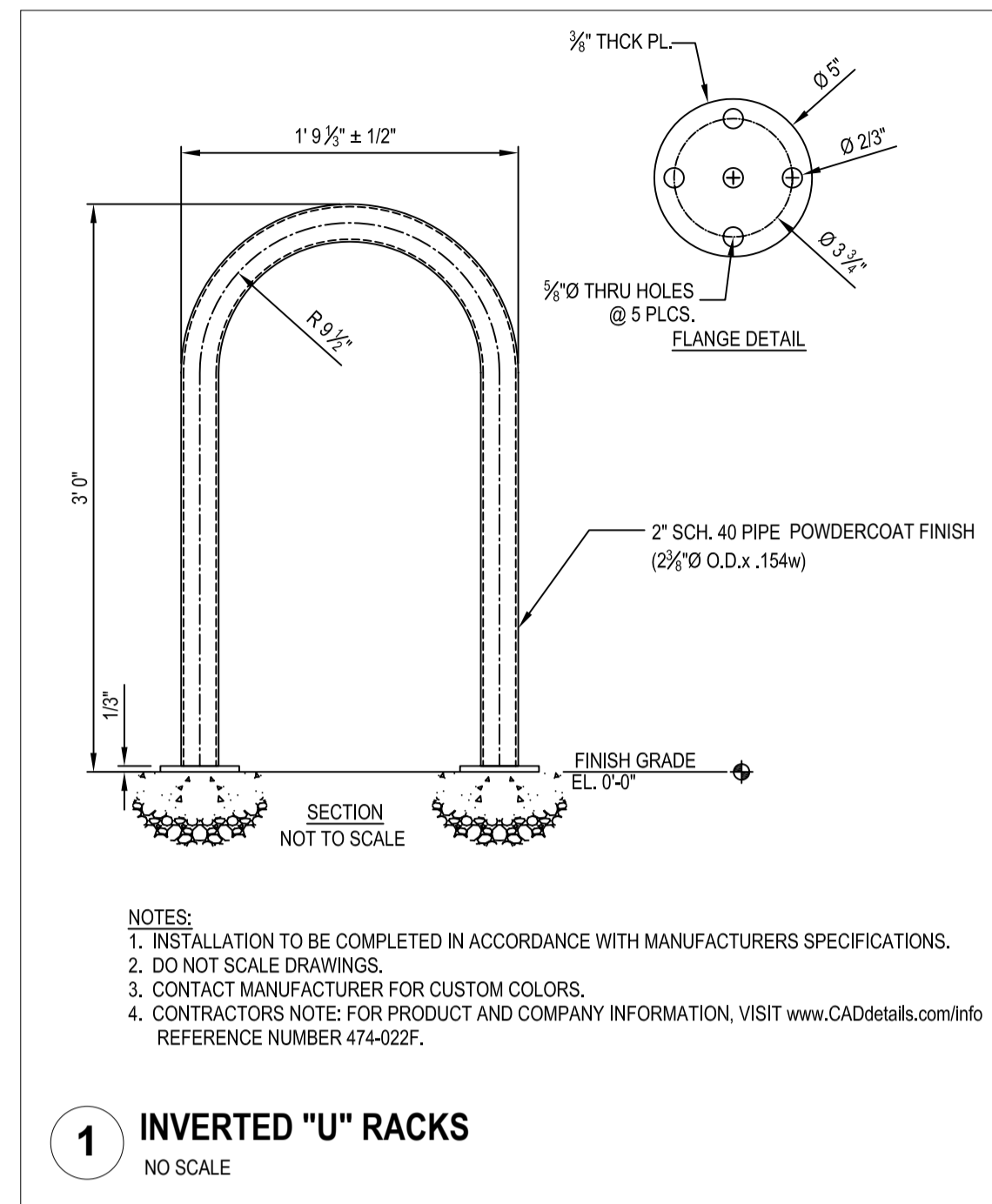

NO.	DESCRIPTION	DATE	BY
0	Issued for Development Permit	May 06/24	CR
REVISIONS			
CLIENT			
THE WELDING SHOP			
CALGARY		ALBERTA	
PROJECT			
THE WELDING SHOP			
ROCKY VIEW COUNTY		ALBERTA	
TITLE			
SITE DETAILS AND INFORMATION			
PROJECT NO. SR24-799			
DRAWN	DATE		
CGR	JAN. 31, 2024		
CHECKED	DATE		
SJD	----		
SCALE AS NOTED			
DRAWING NO. DP2			